



an EnPro Industries company

# QRNG<sup>®</sup> Series Model QRNG 370

Parts Manual  
Record of Change 104

This manual contains important safety information and must be made available to all personnel who operate and/or maintain this product. Carefully read this manual before attempting to operate or perform maintenance on this compressor.

*Fill Out & Return Warranty Registration Card Located Inside*

Manual No. 50164-104

February 2008 Edition



# INTRODUCTION

This manual provides information for the QRNG Series, Model QRNG 370 natural gas compressor per Record of Change 104.

The Model QRNG 370 natural gas compressor is an aircooled, two stage, two cylinder, pressure lubricated compressor capable of handling inlet pressures of -7.5 PSIG (15 in. mercury) up to 30 PSIG. A maximum of 400 PSIG discharge pressure can be produced (with proper controls and modifications). It has a 6" low pressure bore, a 3.25" high pressure bore x 4" stroke and can be run at 400-900 RPM.

## TABLE OF CONTENTS

Serial Number Identification .....	1
Ordering Replacement Parts .....	1
Crankshaft Group .....	2
Crankcase Group .....	3
Bearing Carrier Group .....	4-5
Connecting Rod & Piston Groups	
low pressure .....	6-7
high pressure .....	8-9
Cylinder & Head Groups .....	10-11
Head Assemblies .....	12-13
Suction Valve Assembly .....	14
Discharge Valve Assembly .....	15
Pneumatic Unloader Assembly .....	16
Control Group .....	17
Gasket Set .....	18
Recommended Spare Parts .....	18
QUIN-CIP Lubricant .....	18
Decals .....	18
Crankcase Lubricant Capacity .....	18

## ORDERING

### REPLACEMENT PARTS

All replacement parts are to be ordered through an authorized Quincy gas application distributor. **Insist on genuine Quincy parts only! Failure to do so may void warranty.**

Prompt service can be rendered on repair parts orders if the following information is given:

- Item 1)** the model number, record of change number, & serial number.
- Item 2)** the exact part number needed. (Do not order by item numbers.)
- Item 3)** the exact quantity needed.
- Item 4)** the preferred type of transportation.

## MODEL & SERIAL NUMBER IDENTIFICATION

Record of Change No.

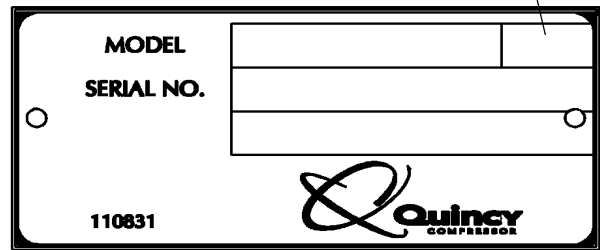

Model & Serial Number Identification Tag

The serial number identification tag is located on the handhole plate side of the crankcase. *Fill in the numbers from your compressor in the corresponding spaces provided here, and reference this page when ordering replacement parts.*

## CHANGES

since previous printing dated December, 2007:

Head unloader piping was modified.

**CAUTION !**

Follow all safety precautions outlined in the QRNG Series instruction manual.

**WARNING !**

Do not operate this compressor without a totally enclosed belt guard or any other required safety equipment.

**DANGER !**

Air used for breathing or food processing must meet OSHA 1910.134 or FDA 21 CFR 178.3570 regulations. Failure to do so may cause severe injury or death.

# CRANKSHAFT GROUP 110630

Item Number	Qty.	Part Number	Description
1	1	111238X001	crankshaft assembly
1.1	1	111238R	crankshaft (N.S.S.; order 111238X001)
1.2	1	2788	bearing cone
1.3	1	40775	bearing cone
1.4	1	110234	orifice, 1/8 npt
1.5	2	2755S	pipe plug, 1/8 npt
1.6	1	110705-F17	roll pin, 3/16 x 1.38
2	1	110523X	sheave assembly
2.1	1	5836R	sheave, 19-1/2", 4G, B sect, ccw (N.S.S.; order 110523X)
2.2	2	110983-N22	hex. screw, 1/2-13 unc x 3.50, grade 8 (@ 90 ft.-lbs.)
2.3	2	116124-N02	square nut, 1/2-13 unc
2.4	2	110428N050	flatwasher, 1/2
3	1	1466	taper key

N.S.S. = Not Sold Separate

@ Indicates torque value (dry threads)

Note: For reversal of compressor rotation refer to QRNG instruction manual.

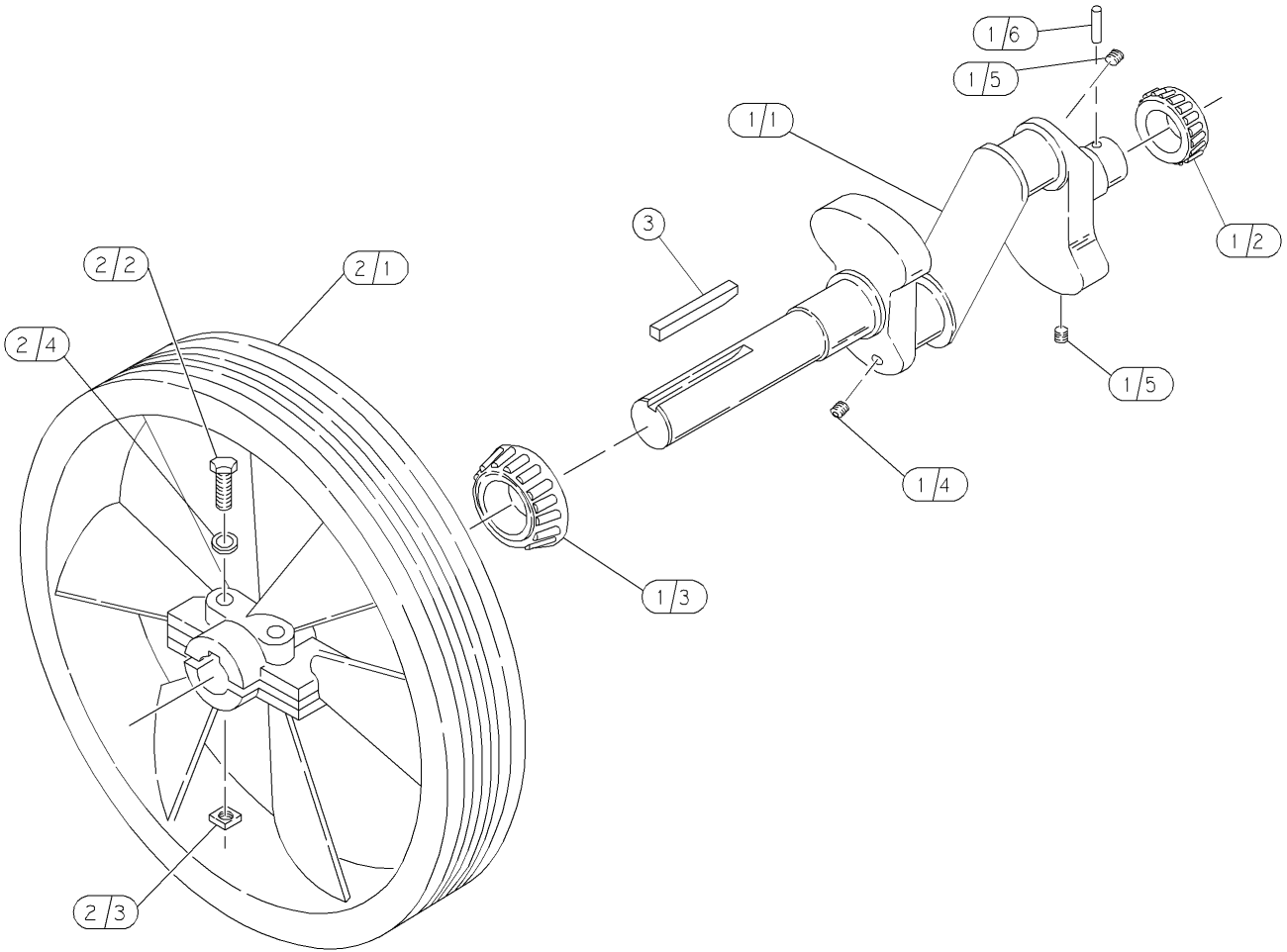

# CRANKCASE GROUP 112047-001

Item Number	Qty.	Part Number	Description
1	1	6904X	crankcase assembly
1.1	1	6904R	crankcase
1.2	1	3720	bearing cup
2	1	2057	pipe plug, 1/2 npt
3	*	1383	bearing adjustment shim, .005 steel
4	*	1383A	bearing adjustment shim, .007 steel
5	*	1383B	bearing adjustment shim, .020 steel
6	*	1383D	bearing adjustment shim, .002 steel
7	1	112066-001	bearing adjustment plate assembly
7.1	1	112066	adjustment plate
7.2	1	112048	oil seal
8	4	123478-L14	hex. screw, 3/8-16 unc x 1.25, grade 5 (@ 30 ft.-lbs.)
9	2	1315-1	gasket, inspection plate
10	1	1249-1	inspection plate
11	1	6849-2	inspection plate (with oil filler)
12	12	123478-K12	hex. screw, 5/16-18 unc x 1.00, grade 5 (@ 12 ft.-lbs.)
13	1	111876-2	oil gauge
14	1	5783	breather ball
15	1	5932	drive pin
16	12	110428N031	flatwasher, 5/16
17	1	22749-042	"o"ring, 1/16 wide x 3.38 o.d.
18	1	112033-908	"o"ring, 3/32 wide x .82 o.d.

\* Quantity as required

@ Indicates torque value in foot pounds (dry threads)

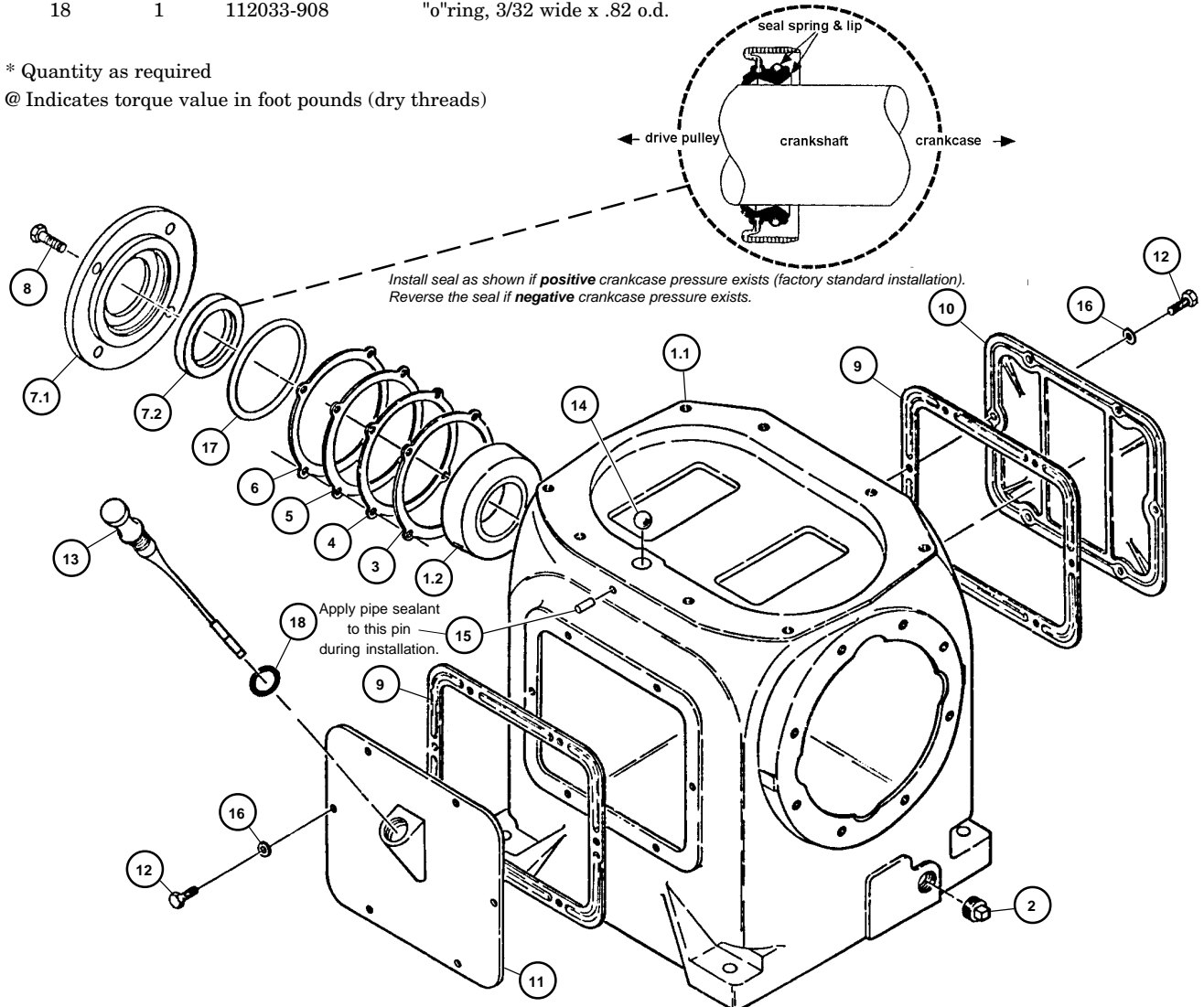

# BEARING CARRIER GROUP 112042-001

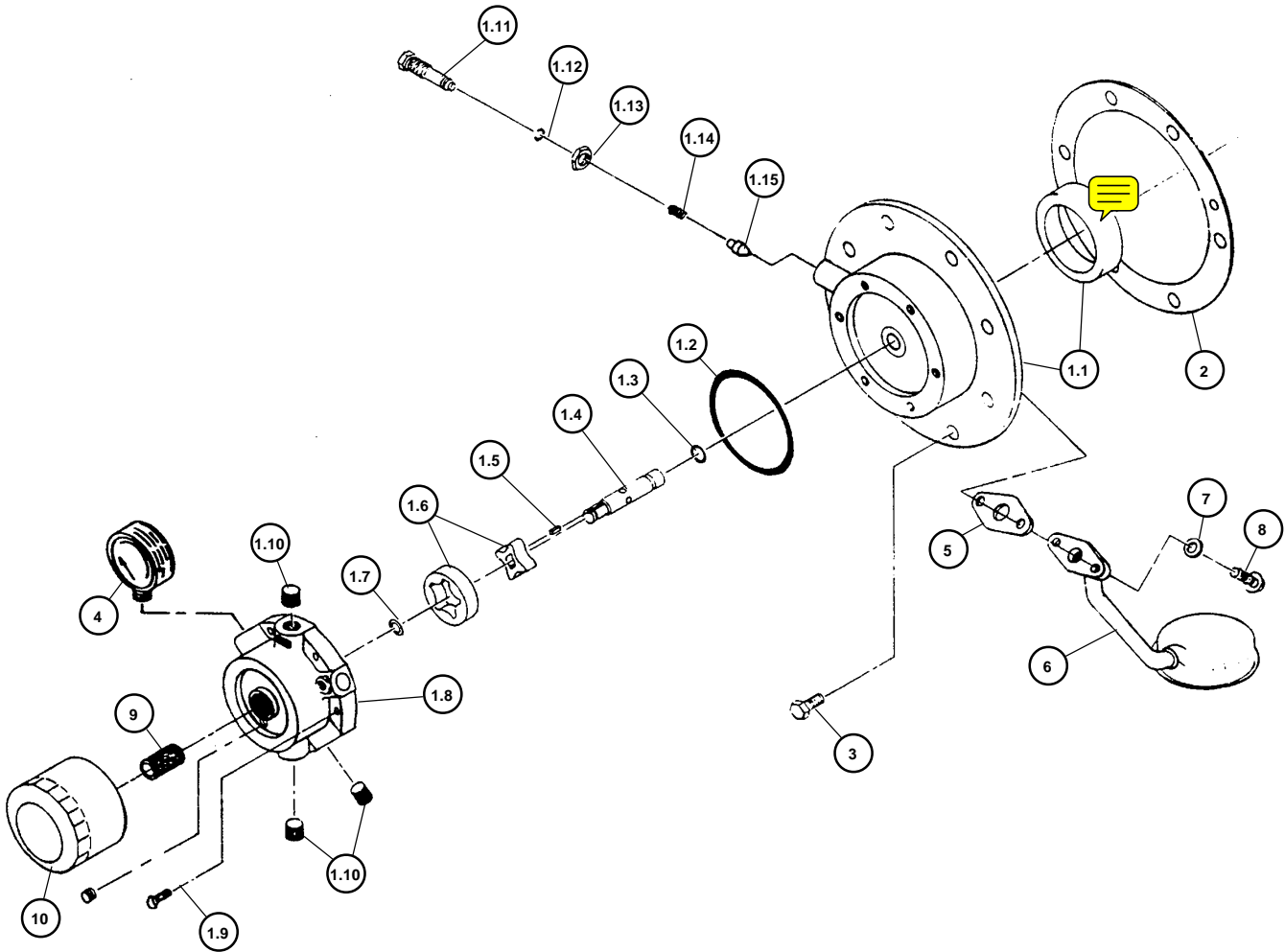

# BEARING CARRIER GROUP 112042-001

Item Number	Qty.	Part Number	Description
1	1	112043-002	bearing carrier assembly (N.S.S.; order 112043G002)
1.1	1	110812	bearing carrier
1.2	1	22749-152	"o"ring, 3/32 wide x 3.44 o.d.
1.3	1	22749-112	"o"ring, 3/32 wide x .69 o.d.
1.4	1	160002-001	bearing carrier driveshaft
1.5	1	160075-001	driveshaft key
1.6	1	160003	pump gerotor
1.7	1	6285	retaining ring
1.8	1	110813-001	housing
1.9	6	123777-J12	hex. screw, 1/4-20 unc x 1.00, grade 5 (@ 6 ft.-lbs.)
§ 1.10	3	2719	pipe plug, 1/4 npt, hex socket
1.11	1	5489	adjustment screw
1.12	1	22749-011	"o"ring, 1/16 wide x .44 o.d.
1.13	1	124369-P02	jamnut, 9/16-18 unf
1.14	1	1160	spring
1.15	1	112857	needle valve
2	1	5502-1	bearing carrier gasket
3	8	123478-L12	hex. screw, 3/8-16 unc x 1.00, grade 5 (@ 30 ft.-lbs.)
§ 4	1	*110822	oil pressure gauge
5	1	6679-1	gasket, oil inlet bracket
6	1	110659	oil pickup tube
7	2	123115-06C	lockwasher, 3/8
8	2	123478-L11	hex. screw, 3/8-16 unc x .88, grade 5 (@ 25 ft.-lbs.)
9	1	110825	stud
10	1	110814	oil filter

### Maintenance Parts

**160079-001**

**Oil Pump Repair Kit**

includes "o"rings, bearing carrier driveshaft, key, gerotor pump & retaining ring

**112043G002**

**Replacement Bearing Carrier Assembly**

includes bearing carrier assembly & bearing carrier gasket

N.S.S. = Not Sold Separate

@ Indicates torque value (dry threads). Tighten multiple bolts, capscrews & hex nuts in a criss-cross or alternating pattern. Bring each fastener to the recommended torque specification in even increments.

\* Should indicate approximately 25 PSIG at operating pressure.

§ Install with Teflon® tape

# CONNECTING ROD & PISTON GROUP 112050-002

(low pressure)

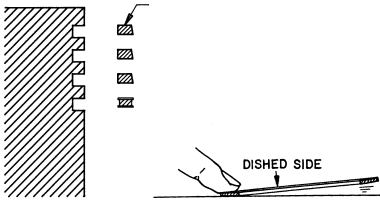

Be sure to stagger ring gaps!

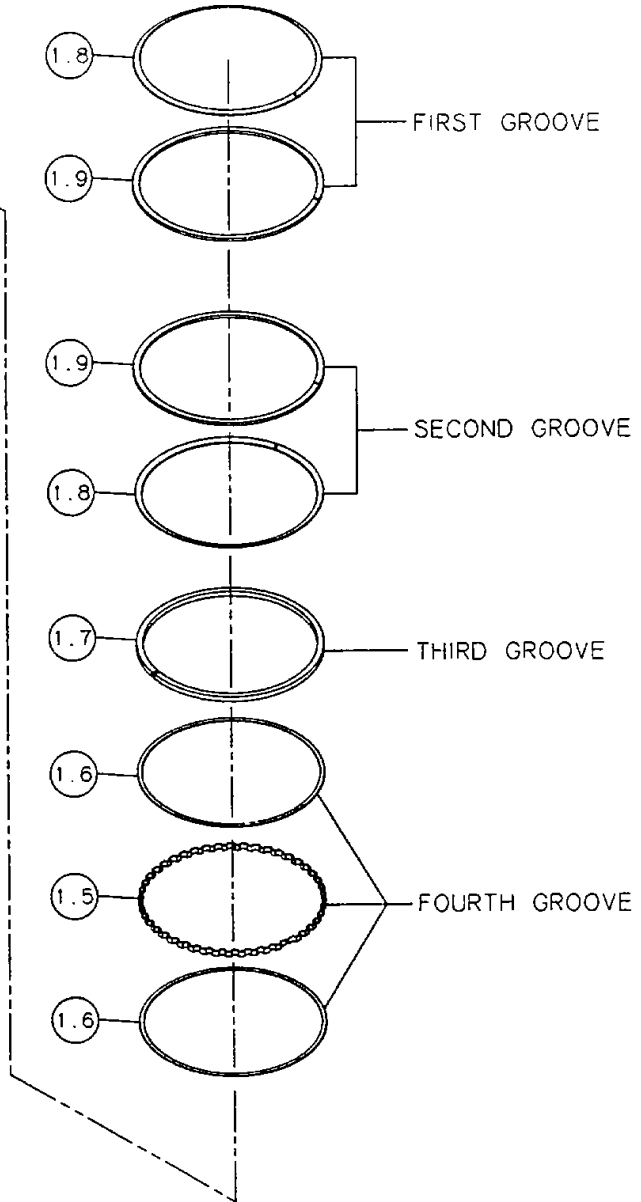
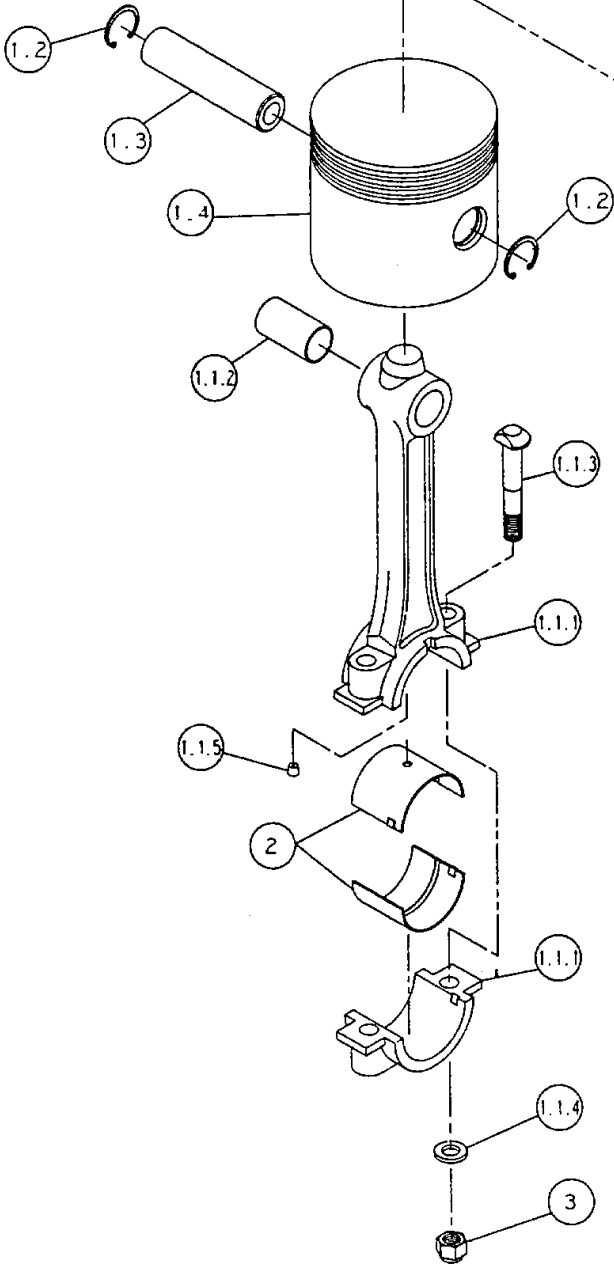



# CONNECTING ROD & PISTON GROUP 112050-002

(low pressure)

Item Number	Qty.	Part Number	Description
1	1	112051X1	connecting rod assembly (N.S.S.; see maintenance parts)
1.1	1	112051-002	connecting rod assembly (N.S.S.; see maintenance parts)
1.1.1	1	112054	connecting rod
1.1.2	1	112234	needle bearing
1.1.3	2	1344	connecting rod bolt, 7/16-20 unc x 3.25
1.1.4	2	1319	connecting rod bolt washer
1.1.5	1	110801-001	orifice
1.2	2	128203-137	retaining ring
1.3	1	110190-019	piston pin
1.4	1	112052	piston
1.5	1	112749	ring spacer
1.6	2	112748	oil ring rail
1.7	1	9146	piston ring
1.8	2	6994	spring
1.9	2	6992	piston ring
2	2	6656	con-rod insert
3	2	124471-M08	locknut, 7/16-20 unf (@ 40 ft.-lbs.)
<b>Maintenance Parts</b>			
	1	112052-010	piston (.010 oversize)
	1	112052-020	piston (.020 oversize)
	* 1	6656PR	connecting rod inserts (1 pair, standard size)
	* 1	6656-010PR	connecting rod inserts (1 pair, .010 undersize)
	1	7527A	<b>Ring Set, LP (standard) No Color Code</b>
	1	5787-010	<b>Ring Set, LP (.010 oversize) (L. Blue)</b> includes all rings necessary for installing .010 oversize piston
	1	5787-020	<b>Ring Set, LP (.020 oversize) (Yellow)</b> includes all rings necessary for installing .020 oversize piston
		<b>112052G001</b>	<b>Piston Assembly (standard)</b> includes piston, pin, ring set & retaining rings
		<b>112052G010</b>	<b>Piston Assembly (.010 oversize)</b> includes piston, pin ring set & retaining rings
		<b>112052G020</b>	<b>Piston Assembly (.020 oversize)</b> includes piston, pin, ring set & retaining rings
		<b>112053G</b>	<b>Replacement Connecting Rod Assembly (standard)</b> includes connecting rod assembly, inserts (pair) & locknuts
		<b>112053G010</b>	<b>Replacement Connecting Rod Assembly (.010 undersize)</b> includes connecting rod assembly, inserts (pair) & locknuts

N.S.S. = Not Sold Separate

@ Indicates torque value (dry threads). Tighten multiple bolts, capscrews & hex nuts in a criss-cross or alternating pattern. Bring each fastener to the recommended torque specification in even increments.

\* One pair required for each connecting rod assembly.

# CONNECTING ROD & PISTON GROUP 112055-001

(high pressure)

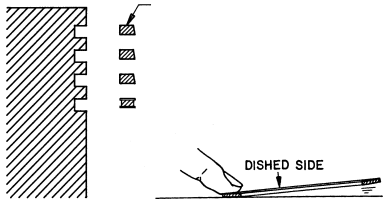

Be sure to stagger ring gaps!

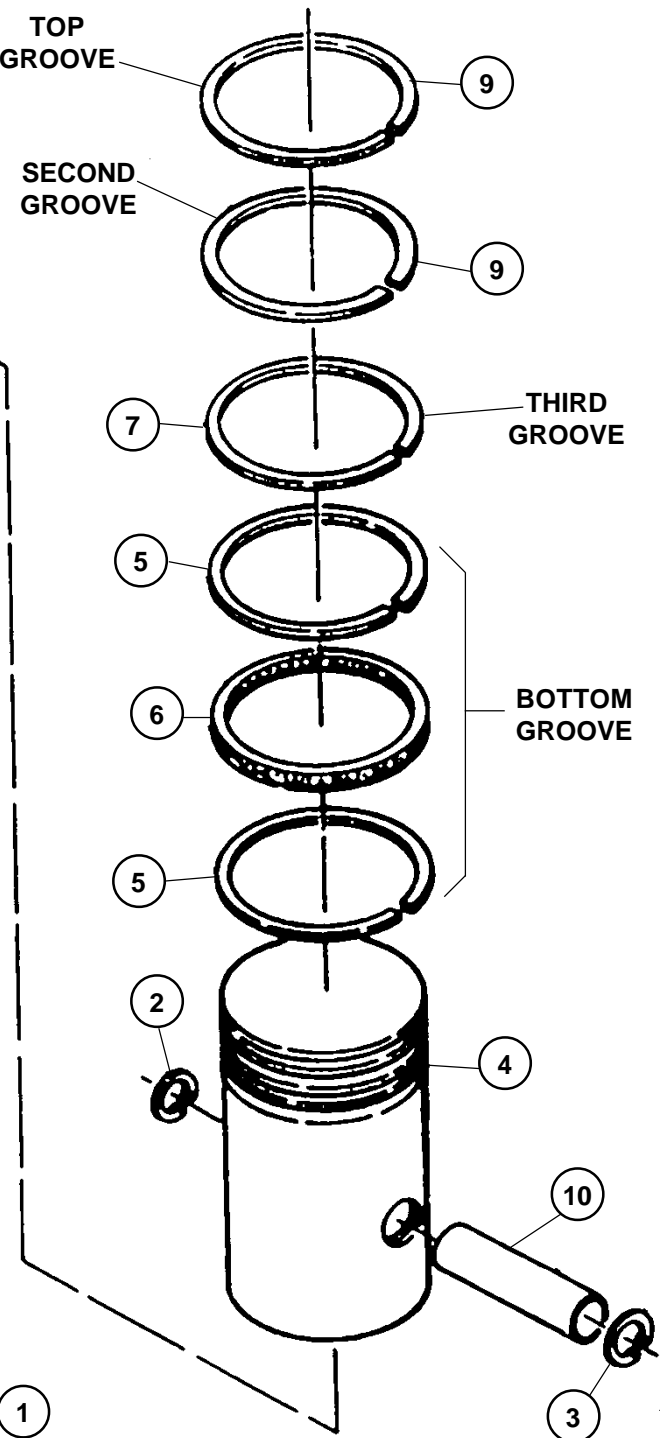
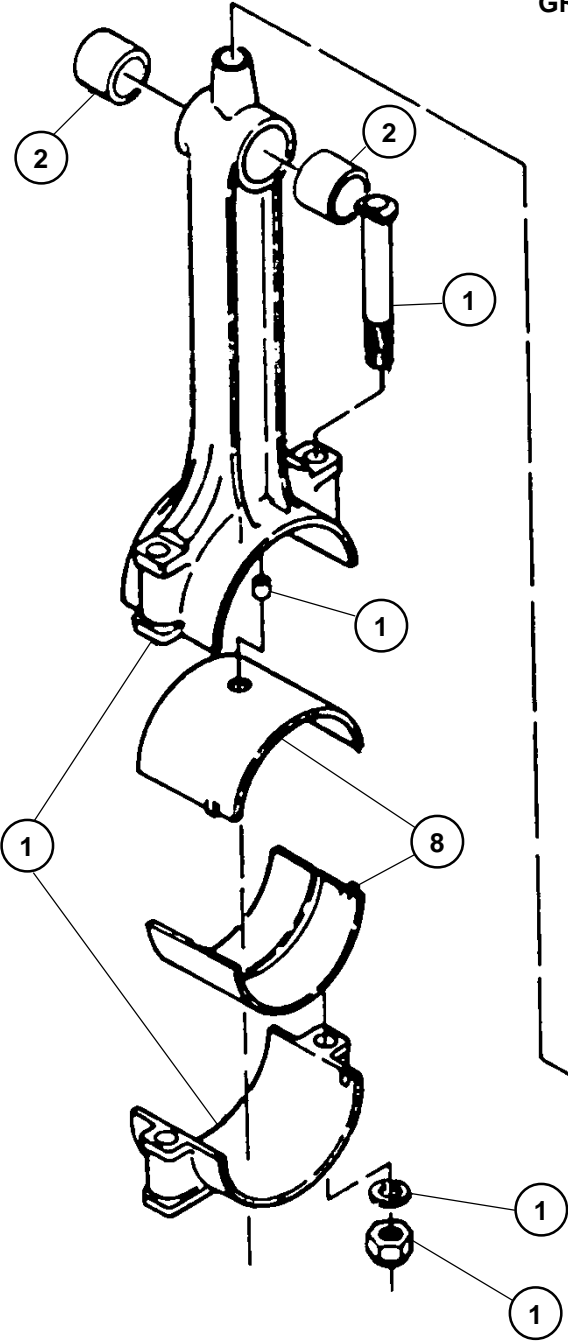

# CONNECTING ROD & PISTON GROUP 112055-001

(high pressure)

Item Number	Qty.	Part Number	Description
1	1	112056-001	connecting rod assembly (N.S.S.; see maintenance parts)
2	2	112059	needle bearing
3	2	8649	retaining ring
4	1	112057	piston
5	2	112782	oil ring rail
6	1	112783	piston ring
7	1	6997	piston ring
8	2	6656	connecting rod insert (sold in pairs only; see maintenance parts)
9	2	111845	piston ring
10	1	110190-020	piston pin
<b>Maintenance Parts</b>			
	1	112057-010	piston (.010 oversize)
	1	112057-020	piston (.020 oversize)
	* 1	6656PR	connecting rod inserts (1 pair, standard size)
	* 1	6656-010PR	connecting rod inserts (1 pair, .010 undersize)
	1	<b>8168A</b>	<b>Ring Set, HP (standard) No Color Code</b> includes piston rings, piston rails, piston spring & spacer
	1	<b>5788-010</b>	<b>Ring Set, HP (.010 oversize) (L. Blue)</b> includes all rings necessary for installing .010 oversize piston
	1	<b>5788-020</b>	<b>Ring Set, HP (.020 oversize) (Yellow)</b> includes all rings necessary for installing .020 oversize piston
		<b>112057G001</b>	<b>Piston Assembly (standard)</b> includes piston, piston pin, ring set & retaining rings
		<b>112057G010</b>	<b>Piston Assembly (.010 oversize)</b> includes piston, piston pin, ring set & retaining rings
		<b>112057G020</b>	<b>Piston Assembly (.020 oversize)</b> includes piston, piston pin, ring set & retaining rings
		<b>112058G</b>	<b>Replacement Connecting Rod Assembly (standard)</b> includes connecting rod assembly, inserts & locknuts
		<b>112058G010</b>	<b>Replacement Connecting Rod Assembly (.010 undersize)</b> includes connecting rod assembly, inserts & locknuts

N.S.S. = Not Sold Separate

@ Indicates torque value (dry threads). Tighten multiple bolts, capscrews & hex nuts in a criss-cross or alternating pattern. Bring each fastener to the recommended torque specification in even increments.

\* One pair required for each connecting rod assembly.

# CYLINDER & HEAD GROUP 115348-007

(plain head)

ITEM	PART NUMBER	QTY	DESCRIPTION
*1	115343P-004	1	HEAD ASSEMBLY,QRNG-350/370
2	7403-1	1	GASKET, HEAD TO CYLINDER
3	5827-3	1	GASKET
*4	8262-1HP	1	CYLINDER,370HP
5	123115-08C	18	LOCKWASHER
6	90386-N15	18	12PT SCREW, 1/2-13 UNC X 1.50, GRADE 8
7	1478-1	2	FLATWASHER
8	5863	2	COUNTERBORE SCREW, 1/2-13 UNC X 4.25, GRADE 8
9	110419-010	1	TUBE FITTING, 90 MALE ELBOW, 3/8 TUBE X 3/8 NPT
10	110428W038	2	FLAT WASHER, 3/8
11	123478-L10	2	HEX SCREW, 3/8-16 UNC X .75, GRADE 5
12	114574-002	3	CLAMP, INTERCOOLER
13	110419-022	2	TUBE FITTING, 90 MALE ELBOW, 1-1/4 TUBE X 1-1/4 NPT
14	115521-1	1	INTERCOOLER
15	110613-001	2	SPACER
16	110428W031	4	FLAT WASHER, 5/16
17	114574-003	1	INTERCOOLER CLAMP
18	123478-K17	2	HEX SCREW, 5/16-18 UNC X 2.00, GRADE 5
MAINTENANCE PARTS			
	115343G002		REPLACEMENT HEAD ASSEMBLY INCLUDES ITEMS 1 AND 2 (1 EACH)
	115521-1K		INTERCOOLER REPLACEMENT KIT INLCUDES ITEM 14 (1 EA) & ITEM 13 (2 EA).

- TIGHTEN ALL BOLTS AND CAPSCREWS IN ANY BOLT PATTERN, EVENLY BRINGING EACH BOLT TO TORQUE IN EQUAL INCREMENTS, WHILE MOVING ABOUT THE BOLT PATTERN.  
\* FOR HEAD AND CYLINDER REPLACEMENT, ORDER 115343HPS HEAD IN LIEU OF 115343HP HEAD, AND 8262-1HPS CYLINDER IN LIEU OF 8262-1HP CYLINDER.

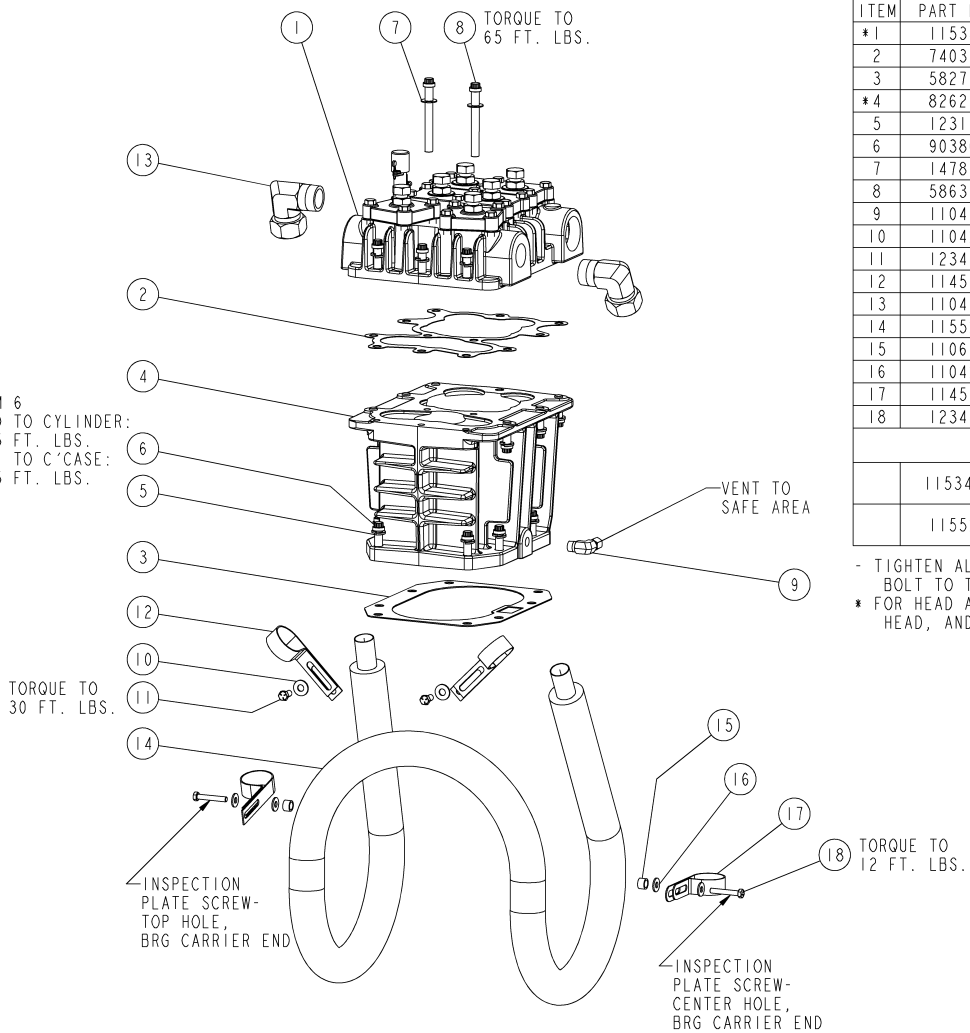

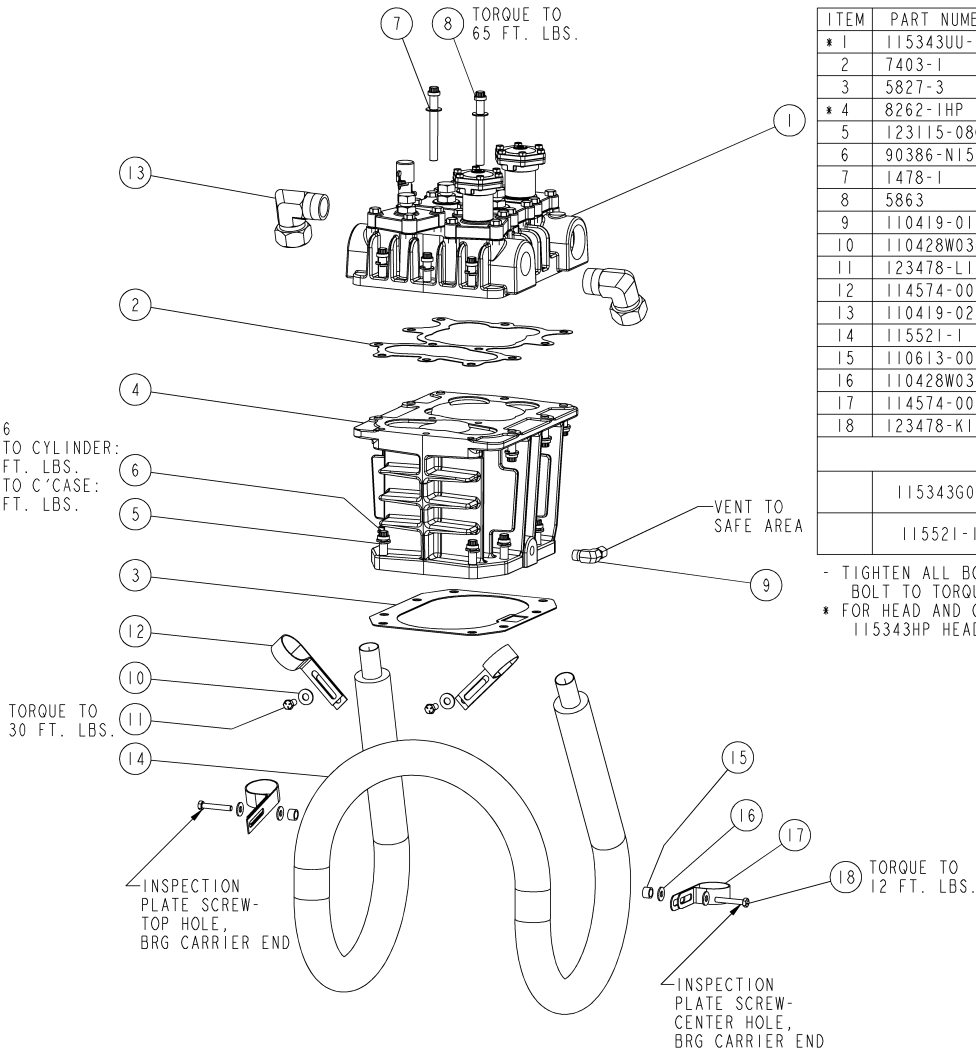

ITEM	PART NUMBER	QTY	DESCRIPTION
* 1	115343UU-005	1	HEAD ASSEMBLY, 350NG/370NG, W/UNLOADERS
2	7403-1	1	GASKET, HEAD TO CYLINDER
3	5827-3	1	GASKET
* 4	8262-1HP	1	CYLINDER, 370HP
5	123115-08C	18	LOCKWASHER
6	90386-N15	18	1/2-13 UNC X 1.50, GRADE 8
7	1478-1	2	FLATWASHER
8	5863	2	COUNTERBORE SCREW, 1/2-13 UNC X 4.25, GRADE 8
9	110419-010	1	TUBE FITTING, 90 MALE ELBOW, 3/8 TUBE X 3/8 NPT
10	110428W038	2	FLAT WASHER, 3/8
11	123478-L10	2	HEX SCREW, 3/8-16 UNC X .75, GRADE 5
12	114574-002	3	CLAMP, INTERCOOLER
13	110419-022	2	TUBE FITTING, 90 MALE ELBOW, 1-1/4 TUBE X 1-1/4 NPT
14	115521-1	1	INTERCOOLER
15	110613-001	2	SPACER
16	110428W031	4	FLAT WASHER, 5/16
17	114574-003	1	INTERCOOLER CLAMP
18	123478-K17	2	HEX SCREW, 5/16-18 UNC X 2.00, GRADE 5
<b>MAINTENANCE PARTS</b>			
	115343G003		REPLACEMENT HEAD ASSEMBLY INCLUDES ITEMS 1 AND 2 (1 EACH)
	115521-1K		INTERCOOLER REPLACEMENT KIT INCLUDES ITEM 13 (1 EA) & ITEM 12 (2 EA).

- TIGHTEN ALL BOLTS AND CAPSCREWS IN ANY BOLT PATTERN, EVENLY BRINGING EACH BOLT TO TORQUE IN EQUAL INCREMENTS, WHILE MOVING ABOUT THE BOLT PATTERN.  
\* FOR HEAD AND CYLINDER REPLACEMENTS, ORDER 115343HPS HEAD IN LIEU OF 115343HP HEAD AND 7395-1HPS CYLINDER IN LIEU OF 7395-1HP CYLINDER.

**CYLINDER & HEAD GROUP 115348-012**  
(head with unloaders)

# HEAD ASSEMBLY 115343P-004 (plain head)

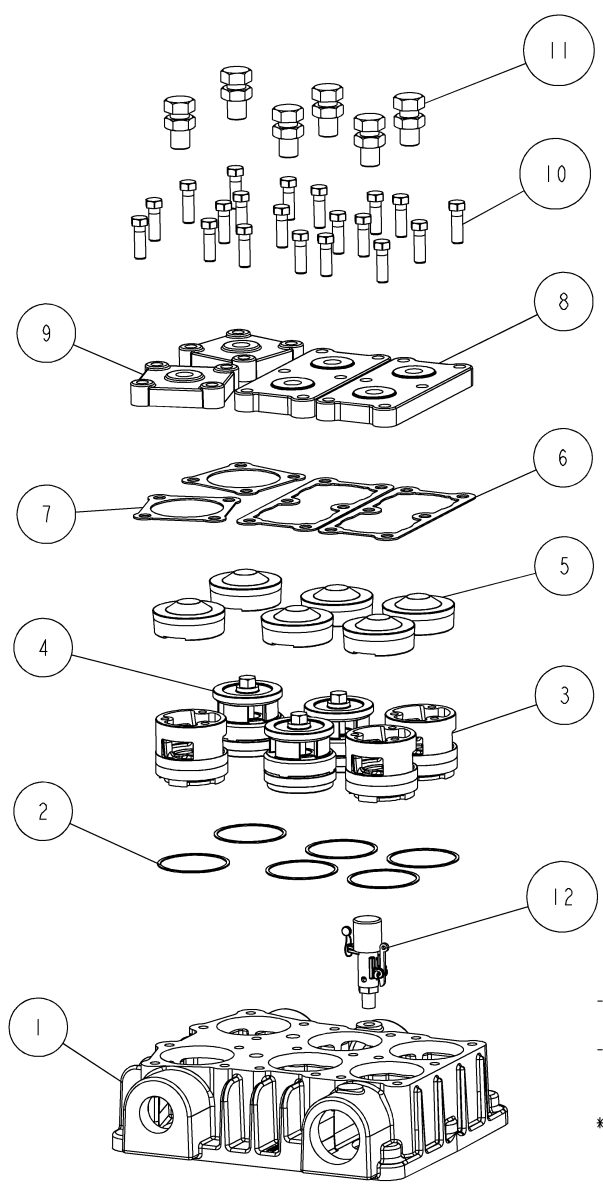

11 TORQUE SCREW TO 60 FT-LBS.  
TORQUE LOCKNUT TO 75 FT-LBS.  
APPLY 272 LOCKTITE DURING ASSEMBLY.

10 TORQUE TO  
50 FT-LBS

12 APPLY 272 LOCKTITE  
DURING ASSEMBLY

ITEM	PART NUMBER	QTY	DESCRIPTION
*1	115343HP	1	HEAD, AIRCOOLED HP
2	2024-001	6	GASKET, VALVE
3	7749X1	3	SUCTION VALVE ASSEMBLY
4	7750X1	3	DISCHARGE VALVE ASSEMBLY
5	6668-1R	6	VALVE RETAINER
6	7398-1	2	GASKET, VALVE COVER
7	2025-1	2	GASKET, VALVE COVER
8	7384	2	VALVE COVER PLATE
9	6666	2	VALVE COVER PLATE
10	7480	20	SCREW, CAP, .44NC X 1.38
11	114545-R15	6	BOLT AND NUT ASSEMBLY
12	111425-225	1	VALVE, RELIEF
MAINTENANCE PARTS			
	7749X1G		REPLACEMENT SUCTION VALVE ASSEMBLY INCLUDES ITEMS 2 AND 3 (1 EACH)
	7750X1G		REPLACEMENT DISCHARGE VALVE ASSEMBLY INCLUDES ITEMS 2 AND 4 (1 EACH)

- TIGHTEN AND TORQUE VALVE COVER PLATE SCREWS (ITEM 11) BEFORE TIGHTENING VALVE CLAMP SCREWS (ITEM 12).
- TIGHTEN MULTIPLE BOLTS, CAPSCREWS AND HEX NUTS IN A CRISS-CROSS OR ALTERNATING PATTERN. BRING EACH FASTENER TO THE RECOMMENDED TORQUE SPECIFICATION IN EVEN INCREMENTS.
- \* FOR HEAD REPLACEMENT, ORDER 115343HPS HEAD IN LIEU OF 115343HP HEAD.

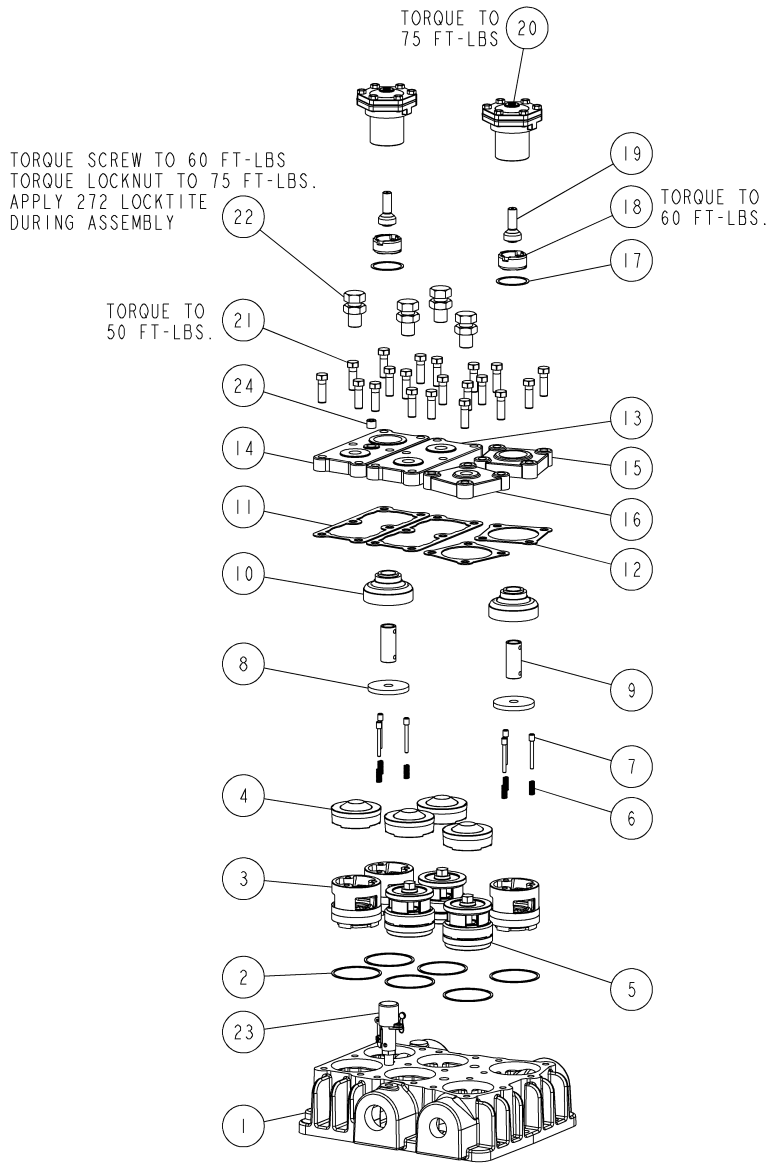

ITEM	PART NUMBER	QTY	DESCRIPTION
* 1	115343HP	1	HEAD, AIRCOOLED HP
2	2024-001	6	GASKET, VALVE
3	7749XI	3	SUCTION VALVE ASSEMBLY
4	6668-1R	4	VALVE RETAINER
5	7750XI	3	DISCHARGE VALVE ASSEMBLY
6	6910	6	SPRING, UNLOAD. PIN
7	1857	6	UNLOADER PIN
8	5729	2	VALVE PLATFORM
9	6912-002	2	UNLOADER PIN
10	6911	2	RETAINER, VALVE
11	7398-1	2	GASKET, VALVE COVER
12	2025-1	2	GASKET, VALVE COVER
13	7384	1	VALVE COVER PLATE
14	7385	1	COVER PLATE
15	6908	1	VALVE COVER PLATE
16	6666	1	VALVE COVER PLATE
17	1556	2	VALVE COVER CAP GASKET
18	3008	2	HOLD DOWN SCREW
19	7532XI	2	UNLOADER PISTON ASSEMBLY
20	40055	2	AY, UNLOADER, PNEUMATIC
21	7480	20	SCREW, CAP, .44NC X 1.38
22	114545-R15	4	BOLT AND NUT ASSEMBLY
23	111425-225	1	VALVE, RELIEF
24	2719	1	PIPE PLUG, 1/4 NPT
MAINTENANCE PARTS			
	7749X1G		REPLACEMENT SUCTION VALVE ASSEMBLY INCLUDES ITEMS 2 AND 3 (1 EACH)
	7749GU		REPLACEMENT SUCTION VALVE ASSEMBLY INCLUDES ITEMS 2 AND 3 (1 EACH), ITEMS 6 AND 7 (3 EACH)
	7750X1G		REPLACEMENT DISCHARGE VALVE ASSEMBLY INCLUDES ITEMS 2 AND 5 (1 EACH)
	7483X1		REPLACEMENT UNLOADER ASSEMBLY INCLUDES ITEMS 17, 19 AND 20 (1 EACH)

- TIGHTEN AND TORQUE VALVE COVER PLATE SCREWS (ITEM 21) BEFORE TIGHTENING VALVE CLAMP SCREWS (ITEM 22).
- TIGHTEN MULTIPLE BOLTS, CAPSCREWS AND HEX NUTS IN A CRISS-CROSS OR ALTERNATING PATTERN. BRING EACH FASTENER TO THE RECOMMENDED TORQUE SPECIFICATION IN EVEN INCREMENTS.
- \* FOR HEAD REPLACEMENT, ORDER 115343HPS HEAD IN LIEU OF 115343HP HEAD.

**HEAD ASSEMBLY 115343UU-005**  
(head with unloaders)

# SUCTION VALVE ASSEMBLY 7749X1

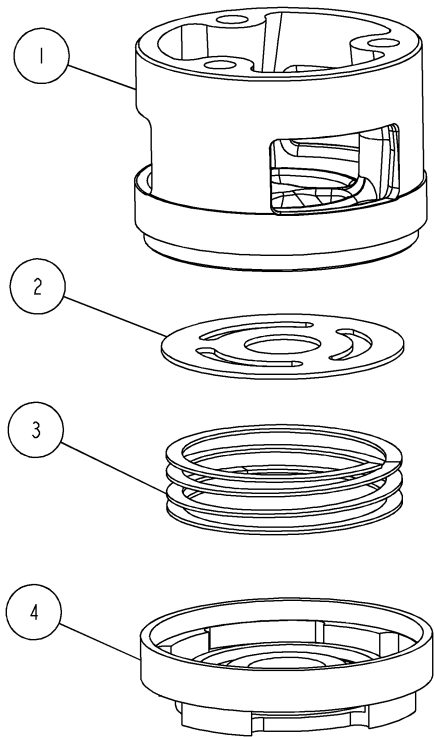

ITEM	PART NUMBER	QTY	DESCRIPTION
1	7749	1	SEAT, SUCTION
2	7753	1	VALVE DISC
3	6909	1	VALVE SPRING
4	7751	1	BUMPER, SUCTION



# DISCHARGE VALVE ASSEMBLY 7750X1

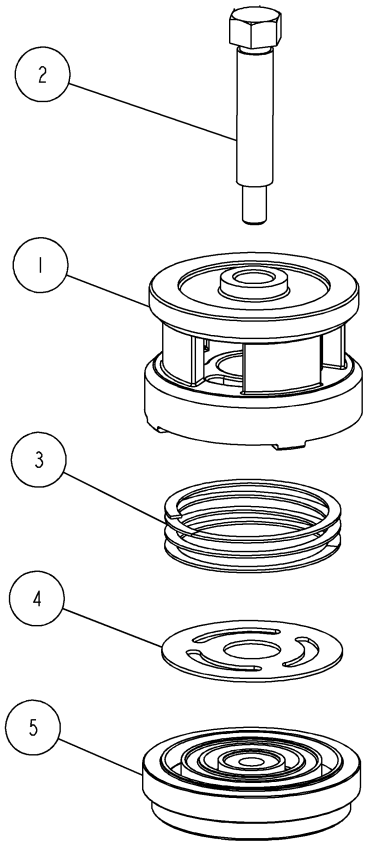

ITEM	PART NUMBER	QTY	DESCRIPTION
1	7752	1	BUMPER, DISCHARGE
2	5746	1	POST, DISCHARGE VALVE
3	6909	1	VALVE SPRING
4	7753	1	VALVE DISC
5	7750	1	SEAT, DISCHARGE

# PNEUMATIC UNLOADER ASSEMBLY 40055

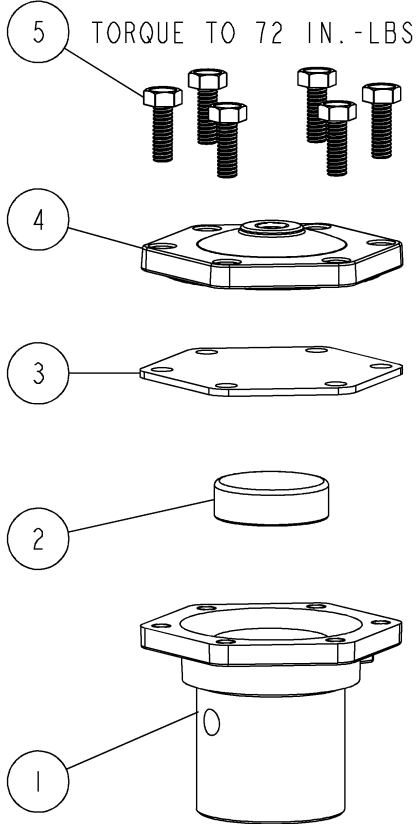

ITEM	PART NUMBER	QTY	DESCRIPTION
1	7483	1	UNLOADER BODY
2	5910	1	UNLOADER CAP
3	1855	1	DIAPHRAGM
4	1818B	1	PLATE, COVER DIAPHRAGM
5	7499	6	SCREW

# CONTROL GROUP 116269-001

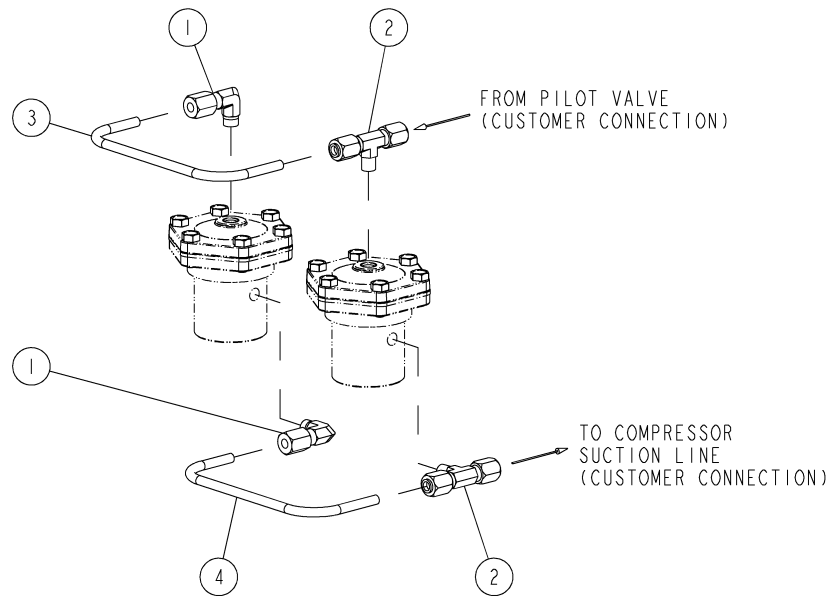

116269-001 GROUP, CONTROL, QRNG UNLOADERS			
ITEM	PART NUMBER	QTY	DESCRIPTION
1	110419-004	2	TUBE FITTING, 90 MALE ELBOW, 1/4 TUBE X 1/8 NPT
2	116268-002	2	TUBE FITTING, MALE BRANCH TEE, 1/4T X 1/8P
3	110421	1	1/4" STEEL TUBE (1 FT)
4	110421	1	1/4" STEEL TUBE (1 FT)

### Recommended Spare Parts

Item #	Qty.	Part Number	Description
	3	7749X1G	replacement suction valve assy.
	3	7750X1G	replacement discharge valve assy.
	1	110822	oil pressure gauge
	1	160079-001	oil pump repair kit
	1	7503G	gasket set

### Gasket Set 7503G

Item #	Qty.	Part Number	Description
	1	5827-3	gasket, cylinder to crankcase
	2	1315-1	gasket, inspection plate
	2	7398-1	gasket
	3	1383	bearing adj. shim, .005 steel
	5	1383A	bearing adj. shim, .007 steel
	3	1383B	bearing adj. shim, .020 steel
	2	1383D	bearing adj. shim, .002 steel
	1	5502-1	gasket, bearing carrier
	1	7403-1	gasket
	6	2024-001	valve gasket
	1	6679-1	oil inlet bracket gasket
	2	2025-1	valve cover gasket

### "O" Ring Kit 110291G

Item #	Qty.	Part Number	Description
	1	112033-908	"o"ring, 3-1/2 wide x .82 o.d.
	1	112048	oil seal
	1	22749-011	"o"ring, 1/16 wide x .44 o.d.
	1	22749-112	"o"ring, 3/32 wide x .69 o.d.
	1	22749-042	"o"ring, 1/16 wide x 3.38 o.d.
	1	22749-152	"o"ring, 3/32 wide x 3.44 o.d.

## DECALS

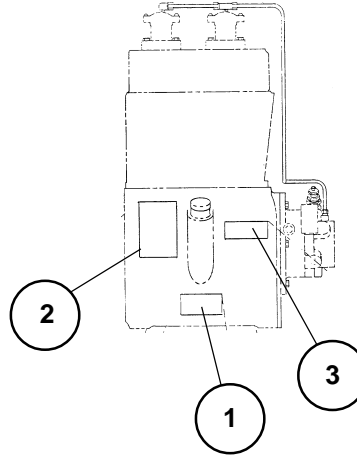

## QUIN-CIP® LUBRICANT

Refer to the chart below to order QUIN-CIP compressor lubricant from your local authorized Quincy distributor.

Package	Part No.	Description
Barrel	112541D032	55 gal., SAE 10W
Pail	112541P032	5 gal., SAE 10W
Gallon	112541G032	1 gal., SAE 10W
Gallon Case	112541X032	(4)-1 gal., SAE 10W
Quart	112541Q032	1 qt., SAE 10W
Quart Case	112541C032	(12)-1 qt., SAE 10W
Barrel	112542D068	55 gal., SAE 20
Pail	112542P068	5 gal., SAE 20
Gallon	112542G068	1 gal., SAE 20
Gallon Case	112542X068	(4)-1 gal., SAE 20
Quart	112542Q068	1 qt., SAE 20
Quart Case	112542C068	(12)-1 qt., SAE 20
Barrel	112543D100	55 gal., SAE 30
Pail	112543P100	5 gal., SAE 30
Gallon	112543G100	1 gal., SAE 30
Gallon Case	112543X100	(4)-1 gal., SAE 30
Quart	112543Q100	1 qt., SAE 30
Quart Case	112543C100	(12)-1 qt., SAE 30

### Decals for QRNG 370 Basic Compressor

Item #	Qty.	Part Number	Description
1	1	110831	serial number & nameplate
2	1	*127889-A	decal, CAUTION!/manual/ "Failure to follow..."
3	1	*127889-B	decal, DANGER! / "Air used for breathing..."
4	1	113387	decal, CAUTION/Do not remove dipstick....

\* Not sold separate; order 127889.

## CRANKCASE LUBRICANT CAPACITY

Model	Less Filter	With Filter
QRNG 370	4 <sup>3</sup> / <sub>4</sub> Qts.	Add 10 oz.

### CAUTION !

Refer to the QRNG Series Instruction Manual for vital lubrication information.

## **QUINCY COMPRESSOR**

### **STANDARD TERMS AND CONDITIONS**

**LEGAL EFFECT:** Except as expressly otherwise agreed to in writing by an authorized representative of Seller, the following terms and conditions shall apply to and form a part of this order and any additional and/or different terms of Buyer's purchase order or other form of acceptance are rejected in advance and shall not become a part of this order.

The rights of Buyer hereunder shall be neither assignable nor transferable except with the written consent of Seller.

This order may not be canceled or altered except with the written consent of Seller and upon terms which will indemnify Seller against all loss occasioned thereby. All additional costs incurred by Seller due to changes in design or specifications, modification of this order or revision of product must be paid for by Buyer.

In addition to the rights and remedies conferred upon Seller by this order, Seller shall have all rights and remedies conferred at law and in equity and shall not be required to proceed with the performance of this order if Buyer is in default in the performance of such order or of any other contract or order with seller.

**TERMS OF PAYMENT:** Unless otherwise specified in the order acknowledgment, the terms of payment shall be 1% 15, net forty-five (45) days after shipment. These terms shall apply to partial as well as complete shipments. If any proceeding be initiated by or against Buyer under any bankruptcy or insolvency law, or in the judgment of Seller the financial condition of Buyer, at the time the equipment is ready for shipment, does not justify the terms of payment specified, Seller reserves the right to require full payment in cash prior to making shipment. If such payment is not received within fifteen (15) days after notification of readiness for shipment, Seller may cancel the order as to any unshipped item and require payment of its reasonable cancellation charges.

If Buyer delays shipment, payments based on date of shipment shall become due as of the date when ready for shipment. If Buyer delays completion of manufacture, Seller may elect to require payment according to percentage of completion. Equipment held for Buyer shall be at Buyer's risk and storage charges may be applied at the discretion of Seller.

Accounts past due shall bear interest at the highest rate lawful to contract for but if there is no limit set by law, such interest shall be eighteen percent (18%). Buyer shall pay all cost and expenses, including reasonable attorney's fees, incurred in collecting the same, and no claim, except claims within Seller's warranty of material or workmanship, as stated below, will be recognized unless delivered in writing to Seller within thirty (30) days after date of shipment.

**TAXES:** All prices exclude present and future sales, use, occupation, license, excise, and other taxes in respect of manufacture, sales or delivery, all of which shall be paid by Buyer unless included in the purchase price at the proper rate or a proper exemption certificate is furnished.

**ACCEPTANCE:** All offers to purchase, quotations and contracts of sales are subject to final acceptance by an authorized representative at Seller's plant.

**DELIVERY:** Except as otherwise specified in this quotation, delivery will be F. O. B. point of shipment. In the absence of exact shipping instruction, Seller will use its discretion regarding best means of insured shipment. No liability will be accepted by Seller for so doing. All transportation charges are at Buyer's expense. Time of delivery is an estimate only and is based upon the receipt of all information and necessary approvals. The shipping schedule shall not be construed to limit seller in making commitments for materials or in fabricating articles under this order in accordance with Seller's normal and reasonable production schedules.

Seller shall in no event be liable for delays caused by fires, acts of God, strikes, labor difficulties, acts of governmental or military authorities, delays in transportation or procuring materials, or causes of any kind beyond Seller's control. No provision for liquidated damages for any cause shall apply under this order. Buyer shall accept delivery within thirty (30) days after receipt of notification of readiness for shipment. Claims for shortages will be deemed to have been waived if not made in writing with ten (10) days after the receipt of the material in respect of which any such shortage is claimed. Seller is not responsible for loss or damage in transit after having received "In Good Order" receipt from the carrier. All claims for loss or damage in transit should be made to the carrier.

**TITLE & LIEN RIGHTS:** The equipment shall remain personal property, regardless of how affixed to any realty or structure. Until the price (including any notes given therefore) of the equipment has been fully paid in cash, Seller shall, in the event of Buyer's default, have the right to repossess such equipment.

**PATENT INFRINGEMENT:** If properly notified and given an opportunity to do so with friendly assistance, Seller will defend Buyer and the ultimate user of the equipment from any actual or alleged infringement of any published United States patent by the equipment or any part thereof furnished pursuant hereto (other than parts of special design, construction, or manufacture specified by and originating with Buyer), and will pay all damages and costs awarded by competent court in any suit thus defended or of which it may have had notice and opportunity to defend as aforesaid.

**STANDARD WARRANTY:** Seller warrants that products of its own manufacture will be free from defects in workmanship and materials under normal use and service for the period specified in the product instruction manual. Warranty for service parts will be Ninety (90) days from date of factory shipment. Electric Motors, gasoline and diesel engines, electrical apparatus and all other accessories, components and parts not manufactured by Seller are warranted only to the extent of the original manufacturer's warranty.

Notice of the alleged defect must be given to the Seller, in writing with all identifying details including serial number, type of equipment and date of purchase within thirty (30) days of the discovery of the same during the warranty period.

Seller's sole obligation on this warranty shall be, at its option, to repair or replace or refund the purchase price of any product or part thereof which proves to be defective. If requested by Seller, such product or part thereof must be promptly returned to seller, freight prepaid, for inspection.

Seller warrants repaired or replaced parts of its own manufacture against defects in materials and workmanship under normal use and service for ninety (90) days or for the remainder of the warranty on the product being repaired.

This warranty shall not apply and Seller shall not be responsible or liable for:

- (a) Consequential, collateral or special losses or damages;
- (b) Equipment conditions caused by fair wear and tear, abnormal conditions of use, accident, neglect or misuse of equipment, improper storage or damage resulting during shipping;
- (c) Deviation from operating instructions, specifications or other special terms of sale;
- (d) Labor charges, loss or damage resulting from improper operation, maintenance or repairs made by person(s) other than Seller or Seller's authorized service station.

In no event shall Seller be liable for any claims whether arising from breach of contract or warranty or claims of negligence or negligent manufacture in excess of the purchase price.

**THIS WARRANTY IS THE SOLE WARRANTY OF SELLERS AND ANY OTHER WARRANTIES, WHETHER EXPRESS OR IMPLIED IN LAW OR IMPLIED IN FACT, INCLUDING ANY WARRANTIES OF MERCHANTABILITY AND FITNESS FOR PARTICULAR USE ARE HEREBY SPECIFICALLY EXCLUDED.**

**LIABILITY LIMITATIONS:** Under no circumstances shall the Seller have any liability for liquidated damages or for collateral, consequential or special damages or for loss of profits, or for actual losses or for loss of production or progress of construction, whether resulting from delays in delivery or performance, breach of warranty, negligent manufacture or otherwise.

**ENVIROMENTAL AND OSHA REQUIREMENTS:** At the time of shipment of the equipment from the factory, Quincy Compressor / Ortman Fluid Power will comply with the various Federal, State and local laws and regulations concerning occupational health and safety and pollution. However, in the installation and operation of the equipment and other matters over which the seller has no control, the Seller assumes no responsibility for compliance with those laws and regulations, whether by the way of indemnity, warranty or otherwise.

June 30, 2003





an EnPro Industries company

**Reciprocating / Systems:** 217.222.7700  
**Air Master** 217.277.0270  
**E-mail:** info@quincycompressor.com  
**Website:** quincycompressor.com  
quincyairmaster.com



© 2006 Quincy Compressor, an EnPro Industries company  
All Rights Reserved. Litho in U.S.A.